



Industrial & Outdoor Commercial LED Lighting Company

4403 Greenbriar Dr, Stafford, Texas 77477  
Tel No. 1-800-8385070  
Monday - Friday 8:30 AM to 5:30 PM

## DIMMABLE LED DOWNLIGHT



### Product Features:

- Energy efficient: save up to 80% in energy costs
- High-lumen output
- Mercury-free
- Instant-on light
- 50,000 hours at 70% lumen maintenance rated life
- CCT: 2700-5000K
- 5 year manufacturer warranty

### Characteristics:

Item Number	D616
Description	5/6" LED down light
Voltage	110-277V AC
Power	14.8W
Dimmable	Non-dimmable
LED Type	SMD
CRI	> 80
Lumens	1050-1200 lms
Color	27/30/35/40/50K
Life time	50,000 hours
Certificate	UL, cUL, Energy Star, FCC, Lighting Facts, LM79, LM80

## Dimensions & Weight

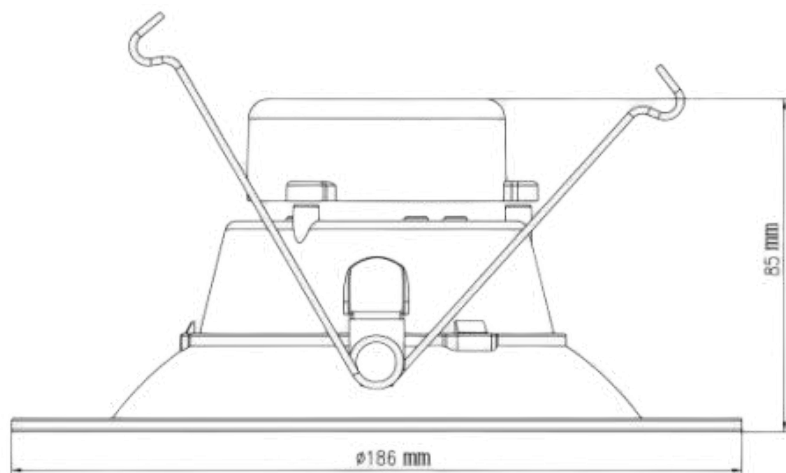

**Size: 185 x 34mm (7.28 x 1.34")**

## Installation

**Install in 3 Easy Steps:**

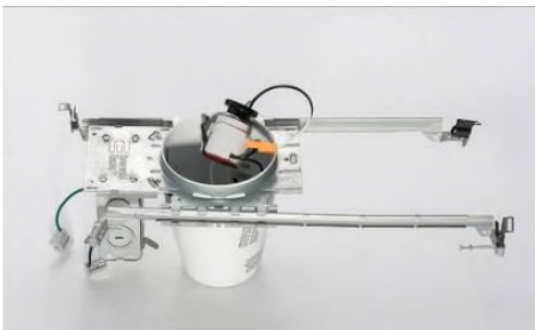

**Step 1: Twist the adaptor into the socket.**

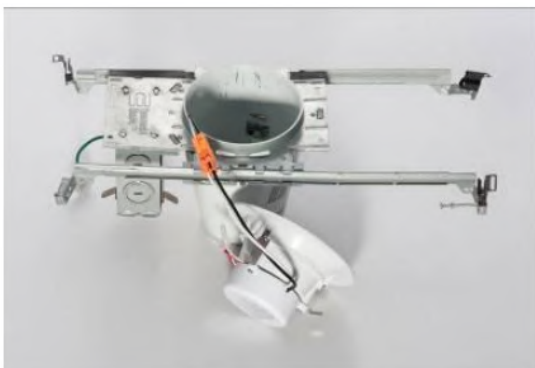

**Step 2: Insert the male connector into the female one.**



**Step 3: Insert LED Trim.**

**Packaging Details**

Size	Carton Size	Pcs/CTN	N.W.	G.W.
6"	56x41x22cm/22.05x16.14x8.66"	12	6kgs/13.23 lb	7kgs/15.43 lb

**Applications**

